

METHOD FOR INFERRING LATENT FUNCTIONS

Hiroki MORI, Toshiharu TAURA, Akira TSUMAYA
Kobe University, Japan

ABSTRACT

Latent functions are functions that are implicitly included in products. A consideration of latent functions at the conceptual design stage has become increasingly important from the perspective of product safety and sustainable manufacturing. This paper discusses and proposes a method to infer the latent functions at the conceptual design stage. First, as a framework to capture the latent functions, the function dividing process is systematized from a linguistic viewpoint into decomposition-based dividing and causal-connection-based dividing. Next, three types of latent function inferring processes are formulated, and the concepts of basic and secondary functions and word match methods are introduced to make the inferring more flexible and appropriate. Finally, a computer system to infer the latent function is developed and a case study is conducted using the system. The case study shows the feasibility of using the proposed method to help designers or consumers to infer latent functions in advance.

Keywords: design engineering, conceptual design, design methods, latent function, function inferring

Contact:

Hiroki Mori
Kobe University
Mechanical Engineering
Kobe
657-8501
Japan
120t374t@stu.kobe-u.ac.jp

1 INTRODUCTION

Latent functions are functions that are included implicitly in products in addition to those that are intended by designers. For example, a chair is designed for the purpose or function of “sitting,” but it may be used as a hanger, with the function of “hanging clothes,” or as a step, with the function of “raising a human higher,” which the designers did not intend as its original purpose. These types of functions are called “latent functions,” which can be defined as “different functions that manifest under different circumstances” (Yoshikawa, 1981).

Latent functions may cause dangerous situations for users. For example, an electric bulb, which is normally used to illuminate a room, has the function of “providing lighting.” However, if a user inadvertently touches it, the latent function of “heating things” is actualized as a “heating hands” function and leads to burned hands. Designers are expected to design products so that such harmful latent functions do not appear.

In addition, latent functions may add new value to a product for users. For example, an empty can may be used as a pen stand by finding the latent function of “gathering pens,” or could be used as a flowerpot by finding the latent function of “planting flowers.” These are examples in which new uses are created by actualizing latent functions. It is expected that the disposal of products would be reduced and their reuse would be improved by considering such latent functions.

As described above, latent functions are useful in the realization of “safety manufacturing” and “sustainable manufacturing.” Hence, when designing products, it is important to examine both the latent functions and visible function, which are functions that are explicitly manifested by the products. Latent functions are functions that are hidden in products, furthermore, “affordance” is also known as the process to discover hidden properties (Norman, 1999). However, the notion of latent functions is different from the notion of affordance because affordance is considered to be focused on the visible properties of products.

The authors previously focused on latent functions that are inherent in products and proposed a method for discovering them (hereafter, referred to as latent function inferring) (Minami et al. 2010). In this study, we attempt to develop a more flexible and appropriate method for inferring latent functions.

2 APPROACH TO LATENT FUNCTION INFERRING

If we follow the above-described definition of a latent function, it is necessary to identify all of the behaviors of a product in order to derive the latent functions. However, it is difficult to find all of the behaviors of a product, particularly when complicated products are designed. In addition, functions are concepts that are subjectively perceived and vary with the individual. Moreover, not all behavior can be latent functions. Therefore, another approach should be developed that is different from directly identifying all of the behaviors in advance.

Let us consider a clue by using the example of a “car.” A car has the latent function of “pressing against the ground.” Here, this latent function can be understood to be represented as a “road roller” function. In other words, the latent functions of a product are thought to be analogized from the functions of other products. On the basis of this consideration, the authors have analyzed the kind of relation that is valid between the target and base products in the analogy framework, wherein the function of the base product can be transferred to the target product (Minami et al. 2010). As a result, it is revealed that the target product (in the above example, a car) and the base product (in the above example, a road roller) ensure a similarity in the lower-level function structure. In the above example, there is a similarity between “engine turns tire,” which is a lower-level function structure of a car, and “engine turns roller,” which is a lower-level function structure of a road roller. This example suggests that the visible function of the base product (a road roller) can be the latent function of the target product (a car) under the condition that both products are able to manifest the same function (“pressing against the ground”) and that both products contain a similar mechanism to realize it. Conversely, it is assumed that the latent function can be analogized by referring to a product with a similar mechanism. In our previous study (Yamamoto et al. 2010), a function was defined as “an entity’s behavior that plays a special role” and was described by using a subject (S), verb (V), and object (O). In addition, for a visible function of a product, $f_1 = (S_1, V_1, O_1)$, a latent function of the same product was defined as a role that appears when the product (S_1) exerts a different movement (V_2) for a different object (O_2).

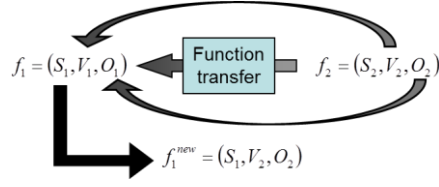

Figure 1. Function transfer

Accordingly, the “function transfer” operation is proposed as a method to find a latent function by “analogy.” In analogical reasoning, the information of objects is usually transferred (Ball and Christensen, 2009). However, in our method, the information surrounding object is also transferred. As shown in Figure 1, this operation replaces verb V_1 and object O_1 of the function $f_1 = (S_1, V_1, O_1)$ (hereafter, referred to as the target function) with verb V_2 and object O_2 of some other function, $f_2 = (S_1, V_2, O_2)$ (hereafter, referred to as the base function). The characteristic of this method is to focus on the similarity between the lower-level functions, which is obtained by decomposing the function into its individual details rather than by examining functions that are observed for the whole product.

In this study, a latent function inferring process is formulated and a computer system is implemented on the basis of the above consideration. In particular, this paper focuses on a method for finding the similarity between lower-level functions. Specifically, we attempt to develop a method to find the similarity between lower-level functions in a flexible way by introducing the “word match” concept, which was developed in our study on the synthesis of functions to determine the subject, verb, and object matches between two functions (Yamamoto et al. 2010), and the concepts of “basic function” and “secondary function,” which have been widely used in the area of value engineering (Miles, 1989), in order to select the most appropriate lower-level function.

3 LATENT FUNCTION INFERRING PROCESS

3.1 Function dividing process

In this study, the similarity between lower-level functions is determined in the “function dividing process” framework that was proposed by the authors. The “function dividing process” is defined as “the process of obtaining the representations for lower-level functions from upper-level functions” and is formulated as follows:

$$m: f_{upper} \rightarrow F_{lower} \quad (1)$$

$$f_{upper} = (S, V, O), F_{lower} = \{f_i \mid f_i = (S_i, V_i, O_i)\}$$

Here, f_{upper} is an upper-level function and F_{lower} denotes the set of lower-level functions. S_i , V_i , and O_i are the subject, verb, and object of a lower-level function.

3.2 Systematization of function dividing process

The function dividing process is divided into two categories: “decomposition-based dividing,” which divides a function by decomposing the upper-level function into the detailed movements or components, and “causal-connection-based dividing,” which divides a function by decomposing the upper-level function through focusing on the causal relations of the involved physical phenomena of the components of the lower-level function.

3.2.1 Decomposition-based dividing

In decomposition-based dividing, the set of the subjects $\{S_i\}$ of the lower-level functions is composed of the components of the subject, S , of the upper-level function; the set of verbs $\{V_i\}$ of the lower-level functions is composed of the movements that realize the verb, V , of the upper-level function. Further, the object of each lower-level function, O_i , is equal to that of the upper-level function, O . This process can be formulated as follows:

$$m_1: f_{upper} \rightarrow F_{lower} \quad (2)$$

$$F_{lower} = \{f_i \mid f_i = (S_i, V_i, O_i), S_i \in S, V_i \in V, O_i = O\}$$

For example, in Figure 2, the lower-level functions “fan blows dust” and “vacuum bag holds dust” are obtained from the upper-level function “vacuum cleaner sucks up dust” by the decomposition-based dividing process. Here, “fan” and “vacuum bag” are components that realize “vacuum cleaner,” while

“blow” and “hold” are movements that realize “suck up.” The object of both lower-level functions is “dust,” which is identical to the object of the upper-level function.

S	vacuum cleaner	
V	sucks up	
O	dust	
Decomposition-based dividing		
fan		vacuum bag
blows		holds
dust		dust
Causal-connection-based dividing		
motor	impeller	vacuum bag
rotates	blows	holds
impeller	dust	dust

Figure 2. Example of function dividing

3.2.2 Causal-connection-based dividing

Two functions are said to be causally connected when the object of one function is equal to the subject of the adjacent function at the same level. In causal-connection-based dividing, the lower-level functions are connected by a chain of causal relations; the object of the terminal lower-level function, O_n , is equal to that of the upper-level function, O . Moreover, the verb of the terminal lower-level function, V_n , is equal to that of the upper-level function, V . This process is formulated as follows:

$$m_2 : f_{upper} \rightarrow F_{lower} \quad (3)$$

$$F_{lower} = \{f_i \mid f_i = (S_i, V_i, O_i), 1 \leq i \leq n, n = |F_{lower}|, S_1 \in S, S_j = O_{j-1} \in S, 2 \leq j \leq n, V_n = V, O_n = O\}$$

For example, in Figure 2, the lower-level functions “motor rotates impeller” and “impeller blows dust” are obtained from the upper-level function “fan blows dust” by the causal-connection-based dividing process. In this case, “motor” and “impeller” are components that realize “fan,” and “motor rotates impeller” and “impeller blows dust” are connected causally because the object “impeller” of “motor rotates impeller” is identical to the subject of “impeller blows fun.” Moreover, the terminal function “impeller blows dust” and the upper-level function “fan blows dust” have the same verb and object.

3.3 Formulation of latent function inferring process

In latent function inferring, the function transfer operation is performed, in which the verb and object of the target function are replaced with those of the base function. This process is formulated on the basis of Figure 1 as follows:

$$l : F_{upper} \rightarrow F_{lower} \rightarrow f_{upper}^{new} \quad (4)$$

$$F_{upper} = \{f_1, f_2\}, f_1 = (S_1, V_1, O_1), f_2 = (S_2, V_2, O_2)$$

$$\text{when } F_{lower}^{f_1} \approx F_{lower}^{f_2}$$

$$f_{upper}^{new} = (S_1, V_2, O_2)$$

Here, F_{upper} denotes the set of the target function (f_1) and base function (f_2), F_{lower} denotes the set of the lower-level functions, $F_{lower}^{f_1}$ denotes the set of the lower-level functions of upper-level function f_1 , $F_{lower}^{f_2}$ denotes the set of the lower-level functions of upper-level function f_2 , and f_{upper}^{new} denotes the latent function obtained by performing the function transfer operation. In the following, we discuss a method to find the similarity between $F_{lower}^{f_1}$ and $F_{lower}^{f_2}$.

3.3.1 Word match

In order to determine the similarity between two functions, we introduce an “abstraction-concretion operation” and “word match.” The “abstraction-concretion operation” consists of an abstraction operation or a concretion operation. The abstraction operation is an operation to obtain an abstract word from a given word by extracting its common and/or essential nature. The concretion operation is an operation to obtain a more concrete word from the given word by clarifying the content of the given word. A set of words, $P(w)$, obtained by performing the abstraction-concretion operation on word w is defined as follows:

$$P(w) = \{w_i | w_i \text{ is a word obtained by abstracting or concreting } w\} \quad (5)$$

Here, suppose w_1 is included in $P(w_2)$, that is, $w_1 \in P(w_2)$. In this case, the relation between w_1 and w_2 is defined as a “superordinate-subordinate relation.” This relation is well known as a hierarchal semantic relation. In addition, “word match” is defined as a situation in which two words are similar through word abstraction-concretion operations. A set of words, $I(w)$, that matches a word, w , is defined as follows:

$$I(w) = \{w_i | w_i = w \vee w_i \in P(w) \vee 0 < |P(w) \cap P(w_i)|\} \quad (6)$$

Between the two functions, when corresponding subjects, verbs, and objects are in the word match situation, they are regarded as similar, and this similar situation is formulated and described as follows:

$$\begin{aligned} f_1 &= (S_1, V_1, O_1), f_2 = (S_2, V_2, O_2) \\ \text{when } S_1 &\in I(S_2) \text{ or } S_2 \in I(S_1), V_1 \in I(V_2) \text{ or } V_2 \in I(V_1), O_1 \in I(O_2) \text{ or } O_2 \in I(O_1) \\ f_1 &\approx f_2 \end{aligned} \quad (7)$$

3.3.2 Basic function and Secondary function

In order to select the most appropriate lower-level function among many pairs of candidates that are similar to each other, we introduce the concepts of “basic function” and “secondary function,” which have been widely used in the area of value engineering (Miles, 1989). A basic function is defined as “the most important function for the upper-level function.” A secondary function is defined as “the function and its lower-level functions that assists and supports the achievement of the basic function.” The basic function can be identified as follows. First, we suppose that the priority to select the function is determined by focusing on the similarity of the verb: some products with verbs that are similar to that of a given product are enumerated and the verbs of their lower-level functions are compared. When a similarity is recognized among these verbs, a function having the verb is identified as the basic function.

For example, in Figure 3, let us find the basic function of “oven.” First, we can enumerate “fan heater,” which contains the verb “heats.” This is similar to (word match) “bakes,” which is the verb of “oven.” Likewise, “hair dryer” has the verb “dries,” which is similar to (word match) “bakes.” Next, their lower-level functions are compared to find a verb that is similar to (word match) the verb “bake” of the lower-level function of “oven.” Here, the verb “heat” of the lower-level functions of “fan heater” and “hair dryer” is detected. Accordingly, we regard “hot air bakes food” as the basic function of “oven.”

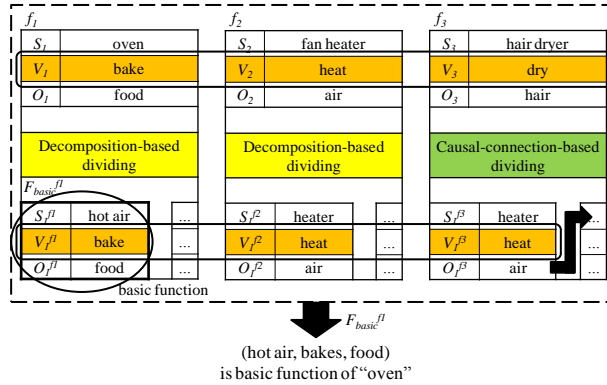

Figure 3. Example of identification of basic function

Based on the above considerations, we formulate the basic function as follows:

$$\begin{aligned} f_1 &= (S_1, V_1, O_1), f_2 = (S_2, V_2, O_2) \\ F_{lower}^{f1} &= \{f_i^{f1}, 1 \leq i \leq m, m = |F_{lower}^{f1}|\}, F_{lower}^{f2} = \{f_j^{f2}, 1 \leq j \leq n, n = |F_{lower}^{f2}|\} \\ f_i^{f1} &= (S_i^{f1}, V_i^{f1}, O_i^{f1}), f_j^{f2} = (S_j^{f2}, V_j^{f2}, O_j^{f2}) \\ \text{when } V_1 &\in I(V_2), V_i^{f1} \in I(V_j^{f2}) \\ F_{basic}^{f1} &= f_i^{f1} \end{aligned} \quad (8)$$

Here, f_1 denotes the upper-level function of a given product, f_2 denotes the upper-level function of another product, F_{lower}^{f1} denotes the set of the lower-level functions of upper-level function f_1 , F_{lower}^{f2} denotes the set of the lower-level functions of upper-level function f_2 , and F_{basic}^{f1} denotes the basic function of f_1 . This determination process is illustrated in Figure 4.

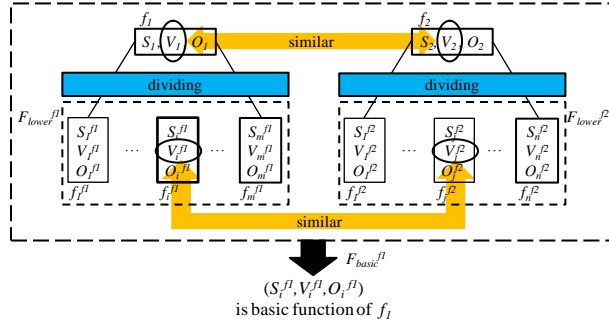

Figure 4. Basic function identifying process

3.4 Classification of latent function inferring process

The latent function inferring process is classified into three types, based on the category of the function dividing process: “latent function inferring in decomposition-based dividing,” “latent function inferring in causal-connection-based dividing,” and “latent function inferring in causal-connection-based dividing and decomposition-based dividing.” Each of these is defined and formulated as follows.

3.4.1 Latent function inferring in decomposition-based dividing

When there are similar functions in the sets of lower-level functions that are obtained from a target function and base function in the decomposition-based dividing and the functions that are recognized to be similar are identified to be the basic function, a latent function can be obtained by using the function transfer.

For example, in Figure 5, “heat pump cools food,” which is the lower-level function of “refrigerator,” and “heat pump cools air,” which is the lower-level function of “dehumidifier,” are similar. If these lower-level functions are identified to be the basic function, “dehumidify air” of “dehumidifier” is transferred to “refrigerator” and the latent function “refrigerator dehumidifies air” is obtained. This latent function suggests the concept of drying food, which is a weak point of a refrigerator.

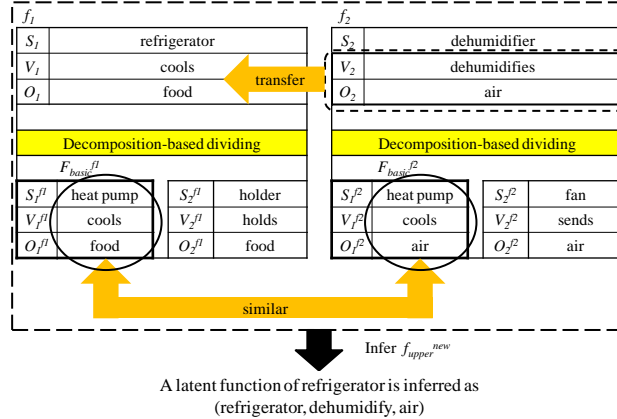

Figure 5. Example of latent function inferring in decomposition-based dividing

This process is formulated as follows:

$$\begin{aligned}
 & \text{in } I_d : F_{upper} \xrightarrow{I_{d1}} F_{lower} \xrightarrow{I_{d2}} f_{upper}^{new} \\
 & F_{upper} = \{f_1, f_2\}, f_1 = (S_1, V_1, O_1), f_2 = (S_2, V_2, O_2) \\
 & F_{lower}^{f_1} = I_{d1}(f_1) = \{f_1^{f_1}, f_2^{f_1}\}, f_1^{f_1} = (S_1^{f_1}, V_1^{f_1}, O_1^{f_1}), f_2^{f_1} = (S_2^{f_1}, V_2^{f_1}, O_2^{f_1}) [O_1^{f_1} = O_2^{f_1} = O_1] \\
 & F_{lower}^{f_2} = I_{d1}(f_2) = \{f_1^{f_2}, f_2^{f_2}\}, f_1^{f_2} = (S_1^{f_2}, V_1^{f_2}, O_1^{f_2}), f_2^{f_2} = (S_2^{f_2}, V_2^{f_2}, O_2^{f_2}) [O_1^{f_2} = O_2^{f_2} = O_2] \\
 & \text{when } f_1^{f_1} \approx f_1^{f_2}, f_1^{f_1} \in F_{basic}^{f_1}, f_1^{f_2} \in F_{basic}^{f_2} \\
 & f_{upper}^{new} = I_{d2}(F_{lower}^{f_1}) = (S_1, V_2, O_2)
 \end{aligned} \tag{9}$$

Here, $F_{lower}^{f_1}$ denotes the set of lower-level functions of upper-level function f_1 on the basis of the decomposition-based dividing, and $F_{lower}^{f_2}$ denotes the set of lower-level functions of upper-level function f_2 on the basis of the decomposition-based dividing. The “latent function inferring in decomposition-based dividing” is illustrated in Figure 6.

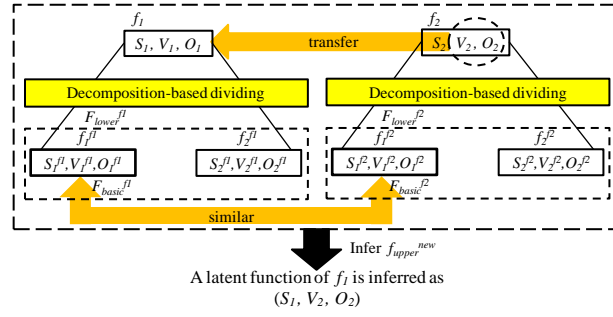

Figure 6. Latent function inferring in decomposition-based dividing

3.4.2 Latent function inferring in causal-connection-based dividing

When there are similar functions in the sets of lower-level functions that are obtained from a target function and base function in the causal-connection-based dividing, and the functions that are recognized to be similar are the basic function or causally connected to the basic function, a latent function can be obtained by using the function transfer.

For example, in Figure 7, “motor rotates chain,” which is the lower-level function of “electric fan,” and “engine rotates chain,” which is the lower-level function of “chainsaw,” are similar. If these lower-level functions are identified to be causally connected to the basic function of each product, “cut object” of “chainsaw” is transferred to “electric fan,” and the latent function “electric fan cuts object” is inferred. This latent function suggests the concept of injury, which is a risk with an electric fan.

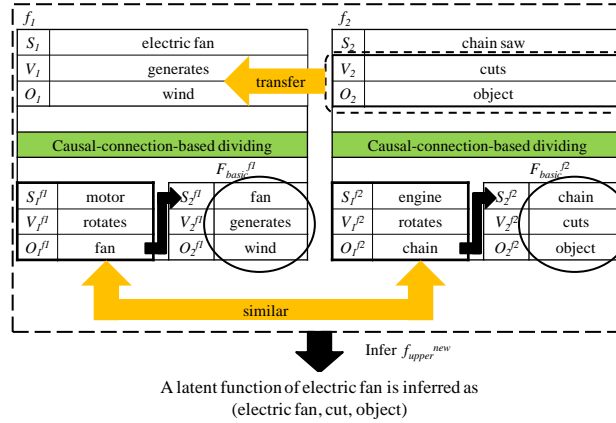

Figure 7. Example of inferring based on causal-connection-based dividing

This process is formulated as follows:

$$in\ l_c : F_{upper} \xrightarrow{l_{c1}} F_{lower} \xrightarrow{l_{c2}} f_{upper}^{new} \quad (10)$$

$$F_{upper} = \{f_1, f_2\}, f_1 = (S_1, V_1, O_1), f_2 = (S_2, V_2, O_2)$$

$$F_{lower}^{f1} = l_{c1}(f_1) = \{f_1^{f1}, f_2^{f1}\}, f_1^{f1} = (S_1^{f1}, V_1^{f1}, O_1^{f1}), f_2^{f1} = (S_2^{f1}, V_2^{f1}, O_2^{f1}) [O_1^{f1} = S_2^{f1}, V_2^{f1} = V_2, O_2^{f1} = O_2]$$

$$F_{lower}^{f2} = l_{c1}(f_2) = \{f_1^{f2}, f_2^{f2}\}, f_1^{f2} = (S_1^{f2}, V_1^{f2}, O_1^{f2}), f_2^{f2} = (S_2^{f2}, V_2^{f2}, O_2^{f2}) [O_1^{f2} = S_2^{f2}, V_2^{f2} = V_2, O_2^{f2} = O_2]$$

$$when\ f_1^{f1} \approx f_1^{f2}, f_1^{f1} \text{ or } f_2^{f1} \in F_{basic}^{f1}, f_1^{f2} \text{ or } f_2^{f2} \in F_{basic}^{f2}$$

$$f_{upper}^{new} = l_{c2}(F_{lower}^{f1}) = (S_1, V_2, O_2)$$

Here, F_{lower}^{f1} denotes the set of lower-level functions of upper-level function f_1 in the causal-connection-based dividing, and F_{lower}^{f2} denotes the set of lower-level functions of upper-level function f_2 in the causal-connection-based dividing. The “latent function inferring in causal-connection-based dividing” is illustrated in Figure 8.

3.4.3 Latent function inferring in causal-connection-based dividing and decomposition-based dividing

When there are similar functions in the sets of lower-level functions, one of which is obtained from a target function in the decomposition-based dividing and the other of which is obtained from a base function in the causal-connection-based dividing, and the functions that are recognized to be similar

are the basic function or causally connected to the basic function, a latent function can be obtained by using the function transfer.

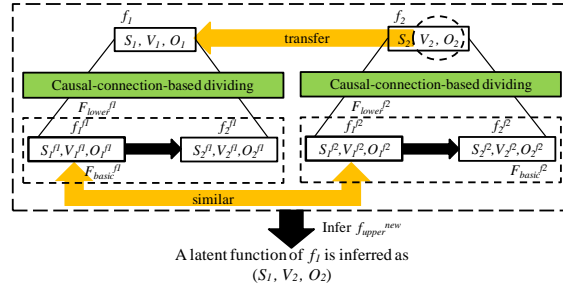

Figure 8. Latent function inferring in causal-connection-based dividing

For example, in Figure 9, “heater boils water,” which is the lower-level function of “electric kettle,” and “heater heats water,” which is the lower-level function of “humidifier,” are the similar. If these lower-level functions are the basic function or causally connected to the basic function, “humidify air” of “humidifier” is transferred to “electric kettle” and the latent function “electric kettle humidifies air” is obtained. This latent function suggests the concept of humidifying a room, which is expected to be a new value for an electric kettle.

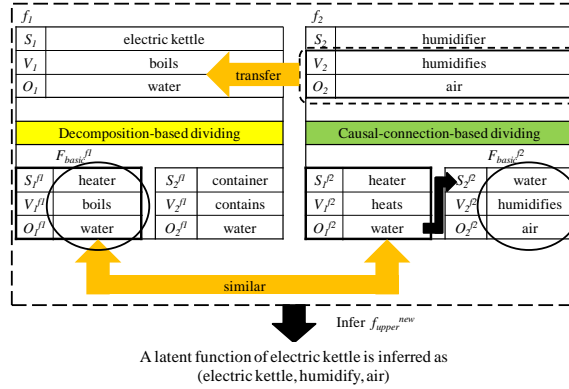

Figure 9. Example of latent function inferring in causal-connection-based dividing and decomposition-based dividing

This process is formulated as follows:

$$in\ l_{dc} : F_{upper} \xrightarrow{l_{dc1}} F_{lower} \xrightarrow{l_{dc2}} f_{upper}^{new}$$

$$F_{upper} = \{f_1, f_2\}, f_1 = (S_1, V_1, O_1), f_2 = (S_2, V_2, O_2) \quad (11)$$

$$F_{lower}^{f_1} = l_{dc1}(f_1) = \{f_1^{f_1}, f_2^{f_1}\}, f_1^{f_1} = (S_1^{f_1}, V_1^{f_1}, O_1^{f_1}), f_2^{f_1} = (S_2^{f_1}, V_2^{f_1}, O_2^{f_1}) [O_1^{f_1} = O_2^{f_1} = O_1]$$

$$F_{lower}^{f_2} = l_{dc1}(f_2) = \{f_1^{f_2}, f_2^{f_2}\}, f_1^{f_2} = (S_1^{f_2}, V_1^{f_2}, O_1^{f_2}), f_2^{f_2} = (S_2^{f_2}, V_2^{f_2}, O_2^{f_2}) [O_1^{f_2} = S_2^{f_2}, V_2^{f_2} = V_2, O_2^{f_2} = O_2]$$

$$when\ f_1^{f_1} \approx f_1^{f_2}, f_1^{f_1} \in F_{basic}^{f_1}, f_1^{f_2} \text{ or } f_2^{f_2} \in F_{basic}^{f_2}$$

$$f_{upper}^{new} = l_{dc2}(F_{lower}^{f_1}) = (S_1, V_2, O_2)$$

Here, $F_{lower}^{f_1}$ denotes the set of lower-level functions of upper-level function f_1 in the decomposition-based dividing and $F_{lower}^{f_2}$ denotes the set of lower-level functions of upper-level function f_2 in the causal-connection-based dividing. This “latent function inferring in causal-connection-based dividing and decomposition-based dividing” is illustrated in Figure 10.

4 DEVELOPMENT OF COMPUTER SYSTEM FOR INFERRING LATENT FUNCTIONS

Based on the method proposed above, we developed a computer system for inferring latent functions. In addition, a product database that contains the function structures of 57 products and an abstraction-concretion word database called WordNet (Fellbaum, 1998) were prepared. In this system, following the input of the target function by the user, its basic function is identified and its latent function can be inferred.

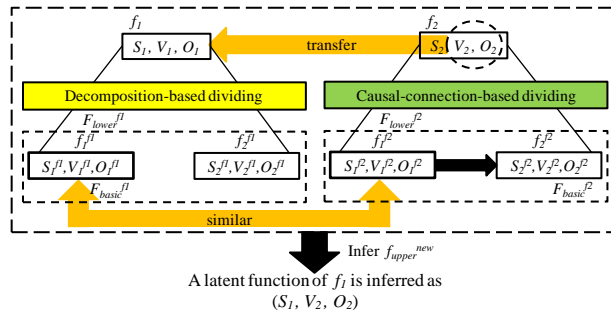

Figure 10. Latent function inferring in causal-connection-based dividing and decomposition-based dividing

In order to confirm the feasibility of the proposed method and developed computer system, we conducted an experiment. By using this computer system, “refrigerator dehumidifies air,” “electric fan cuts object,” and “electric kettle humidifies air,” which were illustrated as examples in the previous section, could be inferred.

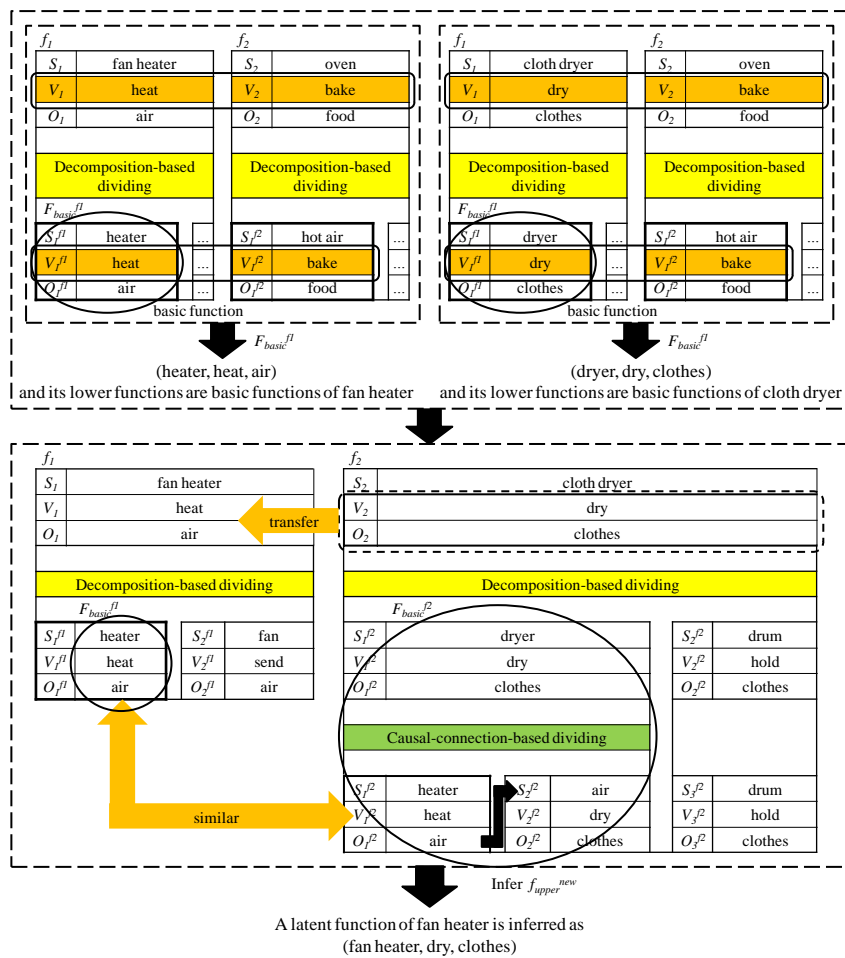

Figure 11. Latent function inferring of “fan heater”

Further, another case study was conducted, as shown in Figure 11. Here, “fan heater” was selected as the target function and “clothes dryer” was selected as the base function. In this inferring process, “heater heats air” and its lower-level functions were first identified as the basic function of “fan heater” by comparing “fan heater” with “microwave oven.” In the same way, “drying mechanism dries clothes” and its lower-level functions were identified as the basic function of “clothes dryer.” Second, the basic function of “fan heater” and the lower-level function of the basic function of “hair dryer” were found to be similar. Accordingly, it was expected that “fan heater dries clothes” could be inferred by the function transfer in the causal-connection-based dividing and decomposition-based dividing.

On the other hand, many inappropriate latent functions were not inferred with the introduction of the basic function concept. For example, “container contains food,” which is a lower-level function of “refrigerator,” and “tray holds food,” which is a lower-level function of “oven,” are similar. Here, if the function transfer is performed, “refrigerator bakes food” is inferred, but this function is inappropriate in common-sense terms. However, in the proposed method, “container contains food” and “tray holds food” were not identified as the basic function of each product. Accordingly, such an inappropriate latent function could be reduced. This result showed the feasibility of the proposed method.

The latent functions “electric kettle humidifies air” and “fan heater dries clothes,” which were inferred in the above examples, suggest new values or new uses for these products. In addition, the latent functions “refrigerator dehumidifies air” and “electric fan cuts object” suggest weak points or risks for these products. Therefore, it is considered that more appropriate and effective designs or uses can be suggested by presenting this information to users or designers in advance.

5 CONCLUSION

In this study, we have proposed and formulated a method for inferring latent functions, in which the concepts of “similarity of functions” and “basic function” were introduced. Based on the proposed method, we developed a computer system for inferring latent functions. From the results of case studies conducted using the system, we confirmed the effectiveness of the proposed method.

On the other hand, some inappropriate latent functions may still be created. We intend to investigate methods for reducing these. In addition, the appropriateness of the created latent functions was evaluated by the authors subjectively. It is necessary to consider the criteria for determining this objectively.

ACKNOWLEDGEMENTS

This work was supported by KAKEN (24603012).

REFERENCES

- Fellbaum, C. (1998) *WordNet: An Electronic Lexical Database*, Cambridge, MA, MIT Press.
- Miles, L.D. (1989) *Techniques of Value Analysis and Engineering* 3rd edition, New York, McGraw-Hill.
- Norman, D. (1999) ‘Affordance, conventions, and design’ *interactions*, vol.6 issue 3, pp.38-43 ACM New York, USA.
- Minami K., Taura T. and Tsumaya A. (2010) ‘A study on modeling of reasoning process considering latent function’ *Design and Systems Division Conference of Japan Society of Mechanical Engineers*, Tokyo, Japan, 27-29 October, pp 202–207 (in Japanese)
- Yamamoto E., Taura T., Ohashi S. and Yamamoto M. (2010) ‘A Method for Function Dividing in Conceptual Design by Focusing on Linguistic Hierarchical Relations’ *Journal of Computing and Information Science in Engineering*, vol.10, September.
- Yoshikawa, H. (1981) ‘General design theory and a CAD system’, in Sata, T. and Warman, E.A. (eds.) (1981) *Man-machine communication in CAD/CAM*, Amsterdam, North-Holland.
- Ball LJ, Christensen BT (2009) ‘Analogical reasoning and mental simulation in design-two strategies linked to uncertainty resolution’, *Design Studies* 30, pp.169-186.