

COOPERATION OF ENGINEERING & INDUSTRIAL DESIGNERS ON INDUSTRIAL PROJECTS

S. Hosnedl, Z. Srp and J. Dvorak

Keywords: engineering design, industrial design, product development, co-operation, design process, methodology

1. Introduction

Many engineering designers and other specialists, (or their captured theoretical and/or practical knowledge), have to affect the constructional structure of a designed technical product to achieve its stated, generally implied and/or obligatory properties [CSN EN ISO 9000], or, to be precise, the required values of the respective property characteristics. Each of these specialists and/or piece of relevant knowledge is important depending on both the general and specific priorities of a property. It is also known that the respective special knowledge, generally called "Design for X - DfX" knowledge, in general "competes". It is a key role and responsibility of an engineering designer to find an optimal or at least suboptimal constructional structure for the designed product. However, the cooperation of engineering and industrial/aesthetic designers has a specific feature - both these professions directly affect the constructional structure of a designed technical product. This means in general the structure, forms and dimensions, materials and ways of production, state of surfaces and tolerances of all its elements. These "product characteristics" are called elemental design properties according to [Hubka&Eder 1988]. However, both these professions have completely opposite priorities when doing it. Engineering designers develop a designed product "from inside to outwards", or in other words "from functions to appearance", while industrial/aesthetic designers do it in quite the opposite way "from outside inwards", i.e. metaphorically "from appearance to functions". The problem is that it must be done simultaneously on the same technical product to be developed. Another significant discrepancy is the qualitatively opposite way that engineering and industrial designers think. While the former have to use more or less rational thinking, the latter use mostly heuristic ways of thinking. Of course exceptions exist, however these only "confirm the phenomenon". The presented paper introduces theory and methodology developed on the basis of a "map" of Engineering Design Science knowledge [Hubka&Eder 1996], [Eder&Hosnedl 2007], which seems to be promising for achieving efficient and effective cooperation even for the two "competing" professions mentioned above. This approach has been validated during education design projects carried out for and evaluated by industrial partners. The projects have been carried out at the Department of Machine Design, University of West Bohemia in Pilsen over the last few years. Students were working in several multiple "competing" teams consisting of both engineering and industrial design students. The following three topics were undertaken last year:

Dentist's working place for the 3rd millennium (Chirana Dental, Piestany, Slovakia)

Assembly line for gluing hinges on mirror doors for bath cabinets (Flabeg, Domazlice, CZ)

- Parking facilities for "Coupe Vehicles" in the project ComplexTrans (Skoda Transportation, Pilsen, CZ)

2. Procedure

The methodology that we present in this paper stems from the engineering design methodology of [Hubka&Eder 1996] based on the theories of technical systems and design processes. This fact makes this methodology different from other methodologies in the sense that it can be used as a “map” of knowledge and not only as “rigid procedural commands” as are often used. However the General Procedural Model of Design Engineering described e.g. in [Hubka&Eder 1996] is strictly focused on engineering design work following the above mentioned “natural” engineering strategy “from functions to appearance”.

The undoubted importance and necessity of close cooperation of engineering and industrial designers in more and more technical fields and respective design projects brought us to the following concept, which in spite of the strong Engineering Design Science base, enables these two contradictory approaches to be combined. Its following description is described in a procedural manner for reasons of simplicity, however all its steps are fully theoretically supported by the Theory of Technical Systems and the Theory of Engineering Design Processes.

Nevertheless, based on the concept [Hosnedl&Vaneek 2001] of Knowledge Integrated Design Engineering (KID) [Hosnedl&Vaneek 2006] each of the steps presented here, including their sub-steps and operations, on the same and other lower hierarchical levels, can be solved in procedural, intuitive or even trial & error & success approaches. This is because the theory based “EDS knowledge map” covers the project as a whole like-an “umbrella” all the time (Figure 1). It enables “jumping” to other “lower” levels at any time if efficient and effective, and again “returning” back to the “EDS knowledge map” to follow the planned strategic path outlined in it for the design project as a whole.

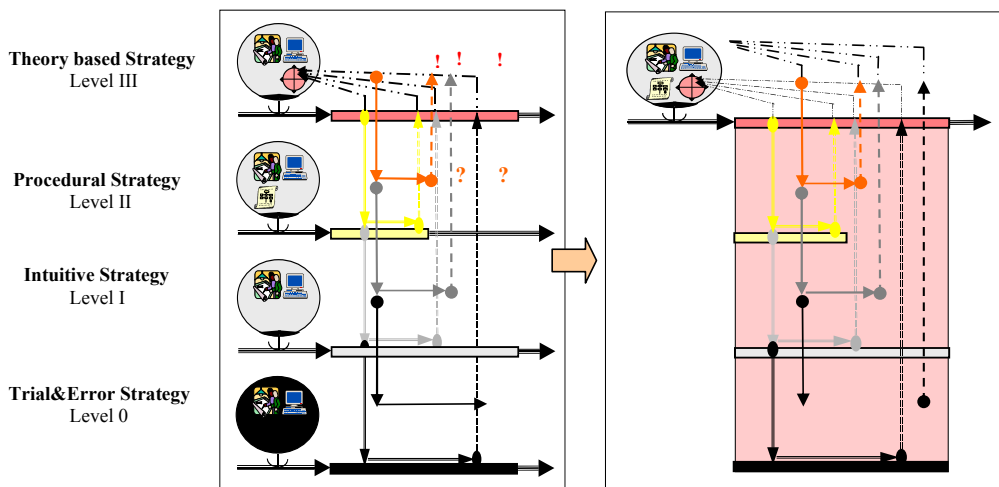

Figure 1. a) Incompatibility of a Procedural Strategy (level II) with the strategy levels I – 0 versus compatibility of the Theory based Strategy (level III) with strategy levels II – 0 (left)
b) Resulting complex strategy of Knowledge Integrated Design Engineering (KID) based on EDS knowledge (right)

2.1 Clarifying and Elaborating the Assigned Task – Integrated engineering and industrial Product Design Specification

As usual this introductory phase [Hubka&Eder 1996] of the project starts with a critical recognition of the assigned problem. Search for State of the Art is mostly focused on collecting information both about the company’s existing product(s) and about competitive product(s) (Figure 2), however corresponding standards, patents, etc. are also investigated.



Figure 2. Company’s own existing product (top left) and competitive products (others) - Example: Dental Chair

A rough examination of the possibilities of realization (feasibility study) is then performed. The resulting stated, generally implied and/or obligatory requirements [CSN EN ISO 9000] of the designed product are completed, classified and quantified in the following step. These should optimally be expressed in the form of the requested and/or maybe not requested values and/or limit values (expressed numerically and/or textually) of property characteristics and/or behavioural characteristics. The “EDS knowledge map” enables a systematic and transparent arrangement of all requirements in relationship to the processes and operators of the life cycle phases of a technical product/system (TS_s) in the form of a series of Transformation Systems (TrfS)

The resulting product design specification document is usually called the List of Requirements. This document generally consists of written formulations of the requirements of the designed product including the textual requirements of its visual appearance (Figure 4 left). In the integrated concept presented here the industrial design students are asked to visualize/predict their correspondingly clearer image of the product’s industrial design (appearance). These first industrial design studies (aesthetic, ergonomic and so forth) (Figure 4 right) become graphic enclosures/extensions of the textual part of the List of Requirements. This helps both engineering and industrial design students to better develop a mutual communication platform and to hold a common course in the subsequent design phases.

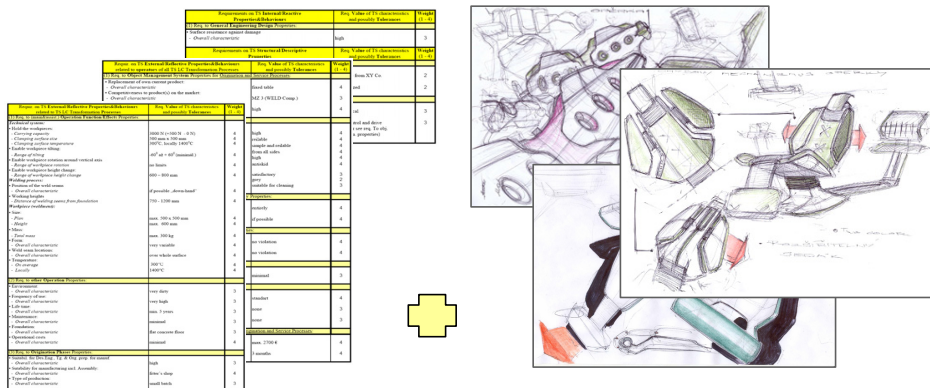

Figure 3. Integrated List of Requirements with textual and graphical parts - Example: Dental Chair

Using the Integrated List of Requirements each team evaluates corresponding (values of characteristics of) properties and behaviours of the “Existing Company Product” (maybe its “thought” representative if any), and evaluates its current (engineering & industrial) design competitiveness by comparing it with at least one “competitive product” (using the weighted point method). Based on these evaluations a simplified SWOT analysis is performed, and decisions about strategic (engineering & industrial

design) priorities and possible risks for the design project are specified. Because of time restraints, more complex business criteria are not considered in these students' projects, nevertheless they are roughly outlined, and can be included in real projects.

A SW programme in MS Excel has been developed to support these specifications and evaluations (Figure 4 - Part 1) including on-line graphs for simplification of the mentioned decisions (Figure 4 - Part 2).

Based on these analyses and the recommended standard/outlined procedural path in the "EDS knowledge map" [Eder&Hosnedl 2007] each team then establishes a rough schedule for their integrated engineering & industrial design work for the project as a whole.

The figure displays a detailed MS Excel spreadsheet used for product design specification and evaluation. The spreadsheet is organized into several sheets, each with a specific focus on different aspects of the welding positioner project. Key sheets include:

- Sheet 1: General Information** - Contains project name, program objectives, and key dates.
- Sheet 2: Design Requirements** - Lists various technical specifications such as 'Design speed', 'Changing position size', and 'Welding positioner', each with associated values and units.
- Sheet 3: Evaluation of Existing Product** - Provides a detailed comparison of the existing product against the design requirements, using a scale from 0 to 5.
- Sheet 4: Evaluation of Competitive Products** - Compares the existing product with several alternative solutions (Comparative solution A, B, C, D, E).
- Sheet 5: Evaluation of New Solution** - Evaluates a new proposed solution against the same design requirements and comparison products.

The spreadsheet uses a color-coded system to highlight different levels of fulfillment and comparison results, facilitating a clear visual analysis of the design options.

Figure 4. Part 1. MS Excel SW support of the Product Design Specification and corresponding evaluation of the Existing Company Product, and its Competitive Product(s) - Example: Welding Positioner

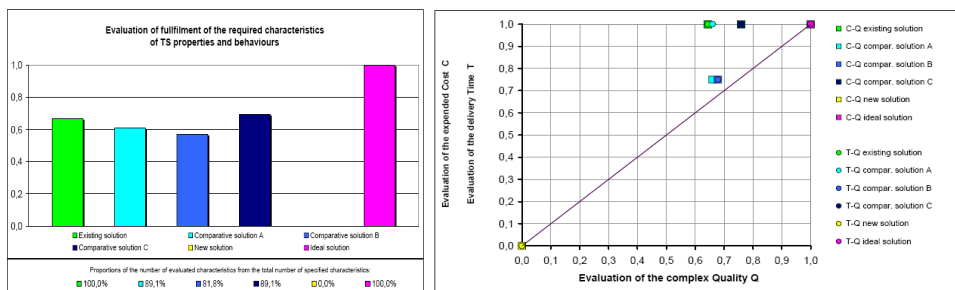

Figure 4. Part 2. MS Excel SW representation of evaluation of the Existing Company Product for the established Product Design Specification (left), and its (engineering&industrial) design competitiveness with the competitive product(s) (right)

2.2 Establishment of the Function Structure and corresponding Industrial Design

Design and analyses of the Operation Process of a designed product serve to establish the optimal transformation functions (i.e. operators' abilities to exert the required effects) needed to perform the designed operations transforming the operand from its input state to the required output state according to the established technology. The optimal Function Structure of the designed technical product, which provides the Operation Process with the established transformation effects (achieved from the established active and/or reactive M, E and I inputs to the operator - technical product) for the main and assisting inputs to the transformation process, is then designed (Figure 5).

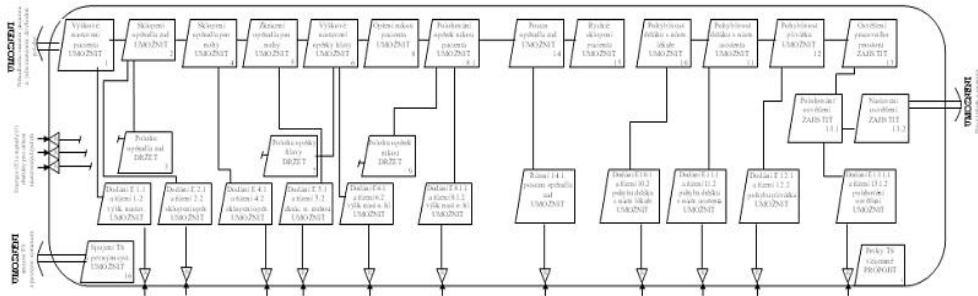

Figure 5. Function Structure of the designed technical product - Example: Dental Chair

Based on the established transformation functions the industrial design becomes an update of the initial industrial design studies made as part of the Integrated engineering and industrial Product Design Specification (paragraph 2.1). Relationships between transformation functions and visual appearance of a product are depicted in Figure 6. All these variants have an identical main transformation function, which is “support a sitting person”. However they have different additional required transformation functions: “enable support of back”, “enable support of arms”, “enable support of head”, “enable support of foot”, and different assisting functions: “enable change of heights”, “enable rotation around vertical axis”, “(fixed, or movable) contact with floor”, etc.



Figure 6. Examples of variants of a technical product which differ in some of their transformation functions - Example: Chair

2.3 Establishment of the Organ Structure and corresponding Industrial Design

The Organ Structure is a concretization of the Function Structure of a product, but it is still an abstract model of the designed technical product. It consists of organs (the carriers of functions) that realize certain modes of action (as the aim), and the relationships between those means [Hubka&Eder 1988]. A generally well-known Organ Structure is a kinematical scheme of a gearbox.

A principle of the work of an industrial designer in this phase can be metaphorically expressed using an example taken from the National Geographic Journal (November 2006). It published an article about the discovery of an ancient young girl who spent 3.3 million years locked in sandstone. It showed a model of the girl's face which gave us an idea of what she may have looked like (“predicted

industrial design”). This model was created by forensic artists based on information obtained from the skull as a part of the skeleton (“organ structure”) as depicted in Figure 7.

A technical equivalent of the example above is shown in Figure 8. Organ structures of the designed product are mostly designed in several alternatives and their variants using the morphological matrix. It enables simple combinations of different organs which were established for fulfilling the respective functions from the established Function Structure. An optimal alternative/variant is then usually selected based on the weighted point evaluation according to the criteria selected from the Product Design Specification. Now, the predicted industrial design of the respective alternatives/variants can be used as one of the evaluation criteria for choosing the optimal variant. Until now this has not been possible in this phase when using only a usual concept without integrating industrial designers.

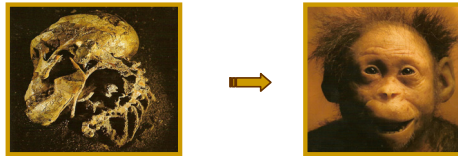

Figure 7. An Example of estimating the appearance of an object from its skeleton

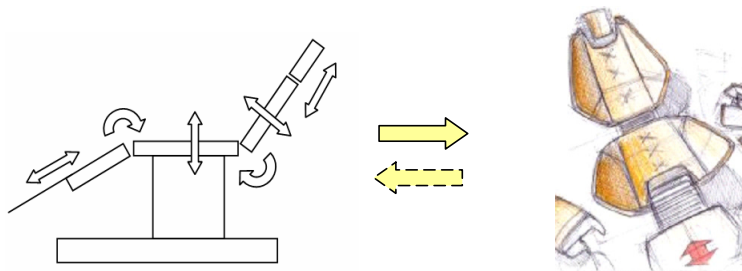

Figure 8. Organ Structure together with its derived/predicted Industrial Design - Example: Dental Chair

2.4 Establishment of the Component Structure - Engineering and Industrial Design

In the final two design phases the engineering and industrial design of the rough component structure (preliminary layout) and final component structure (dimensional layout) of the designed product (Figure 9) for the selected optimal variant(s) of the organ structure are established.

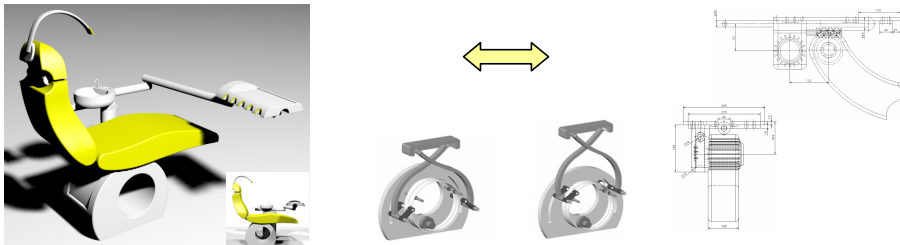

Figure 9. Integrated Engineering and Industrial Design of the Constructional Structure - Example: Dental Chair

Now using the Integrated List of Requirements each team evaluates the achieved/predicted (values of characteristics of) properties and behaviours of the “Newly Designed Company Product”, and evaluates its current (engineering & industrial) design competitiveness by comparing it to at least one

“competitive product” (using the weighted point method). The SW programme in MS Excel mentioned above also supports these evaluations (Figure 10 - Part 1) including on-line graphs for visualisation of the comparisons (Figure 10 - Part 2).

Figure 10. Part 1. MS Excel SW support for evaluation of existing and newly designed company products, and their (engineering&industrial) design competitiveness compared to competitive products - Example: Welding Positioner

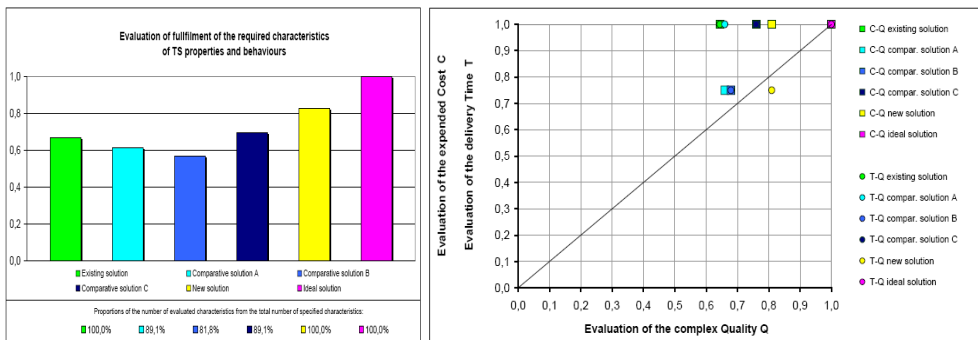

Figure 10. Part 2. MS Excel SW representation of the evaluation of existing and newly designed company products for the established product design specification (left), and their (engineering&industrial) design competitiveness compared to competitive product(s) (right) - Example: Welding Positioner

3. Conclusions

The strategy presented in this paper gives engineering & industrial designers a common platform to consolidate their cooperation. It can also help chief designers to manage their interdisciplinary design teams more efficiently thereby achieving the designed product at a higher quality, lower cost and with a shorter delivery time. This increases the design competitiveness of the product and improves its chances of succeeding in the market place.

In addition to these benefits, this strategy has also proved to have a high pedagogical value. It brings engineering & industrial design students into interdisciplinary teams so they are able to understand the general approach, priorities and work principles of their colleagues from the “competing” design area. This experience also helps them to recognize their roles and responsibilities within a design process. Furthermore, it enables students to gain their own experience in cooperation and communication with different professions, which encourages their discussions and provides them with feedback of how they are able to assert their own ideas in a design team and how they are able to accept the thoughts and ideas of other team members.

This new methodology has been validated in the semestral students' projects carried out at the Department of Machine Design (UWB, Pilsen). The results of the project were presented in a university exhibition called Design² held in the "Over the Stairs" gallery on the university's Bory campus. These projects were greatly appreciated not only by the teachers and students involved but also by the participating industrial and research partners.

The new knowledge presented in this paper will be implemented and continuously improved in the semestral projects which are being undertaken this year (2007):

- Covers for working space of boring and milling machines TOS Varnsdorf (ASTOS, As)
- Emergency bed for very seriously ill patients (LINET, Zelevce)
- Luggage space for estate cars (Skoda Auto, Mlada Boleslav)

It is believed that 'results we achieve will validate further progress' in the theory and methodology presented here, and will contribute to their further development.

Acknowledgements

We are very grateful to the students from the Department of Machine Design of the Faculty of Mechanical Engineering (FME) and Institute of Art and Design (IAD), UWB, Pilsen, for their enthusiastic participation in these interdisciplinary projects. We would also like to express special thanks to our students for allowing us to use their designs to illustrate this paper. The authors of the paper also wish to thank the participating industrial partners – Chirana-Dental s.r.o., Piešťany (SK), Flabeg s.r.o., Domažlice (CZ), and Škoda Transportation s.r.o., Plzeň (CZ), for their technical support which enable us to solve such interesting projects and for their financial grants which provided awards for the best team in each topic, evaluated by joint university and industry committees. This paper includes particular results of the project of the Research Centre of Rail Vehicles, ID 1M0519, No. 1M4977751302 at the University of West Bohemia in Pilsen subsidised by the Czech Ministry of Education and the project No. 101/08/H051 Optimizing of multidisciplinary designing and modelling of production systems subsidised by the Grant Agency of Czech Republic.

References

- [Eder&Hosnedl 2008] Eder, W. E., Hosnedl, S.: *Design Engineering, A Manual for Enhanced Creativity*. CRC Press, Taylor & Francis Group, Boca Raton, Florida USA, 2008, 588 p., ISBN 978-1-4200-4765-3
- [Eekels 2000] Eekels, J., 'On the fundamentals of engineering design science', Part 1, *Journal of Engineering Design*, Vol.11, No.4, 2000 pp 377 – 397,
- [Hosnedl&Vanek 2001] Hosnedl, S., Vaněk, V.: *Design Science for Engineering Design Practice*. In: *Proceedings of International Conference on Engineering Design – ICED 01*. Glasgow, UK: IMechE, London, 19.-25.8.2001. Vol 3, s. 363-370. ISBN 1 86058 1.
- [Hosnedl&Vanek 2006] Hosnedl, V., Vanek, V.: *Engineering Design Science based Design Research for Education and Practice*. In: *Special Issue of the Selected Articles (4 Best Paper Awarded and 10 being come up for the Best Paper Award) of the 1st Conf. on Design Engineering and Science – ICDES2005*. Vienna, Austria: Japan Soc. for Design Eng. and TU Vienna, (28.–31.10.2005, p. 63 - 68.). ISSN 0919-2948. Tokio: Japan Society for Design Engineering, 2006, p. 31-36
- [Hubka&Eder 1988] Hubka, V., Eder, W.E.: *Theory of Technical Systems*. Berlin Heidelberg: Springer - Verlag, 1988, (2nd ed. in German. 1984) ISBN 3-540-17451-6
- [Hubka&Eder 1996] Hubka, V., Eder, W.E.: *Design Science*. London, Springer, 1996, ISBN 3-540-19997-7
- [CSN EN ISO 9000] ČSN EN ISO 9000 (ed. 2, 01 0300, idt ISO 9000:2000) *Quality management systems – Fundamentals and vocabulary*. Prague: Czech Institute for Standardisation, 2002

Stanislav Hosnedl, Professor, Dr.-Ing.
University of West Bohemia, Faculty of Mechanical Engineering,
Department of Machine Design
Univerzitni 8, 306 14 Pilsen
Czech Republic
Tel.: +420 377 638 266,
Fax.: +420 377 638 202,
E-mail: hosnedl@kks.zcu.cz